

# Aliphatic Phenylene Vinylene Copolymers: Tuning the Color of Luminescence through Co-monomer Feed Ratios

M. Hay and F. L. Klavetter\*<sup>‡</sup>

Contribution from the UNIAX Corporation, Santa Barbara, California 93117

Received February 22, 1995<sup>⊗</sup>

**Abstract:** By introducing co-monomers with flexible linker groups into a step growth condensation route to poly(phenylene-*alt*-vinylene) (PPV), a series of solution-processible PPV copolymers is prepared. Peak photoluminescence of these copolymers systematically ranges from about 2.25 to 2.75 eV (yellow-green to blue), increasing in energy upon increasing flexible linker content. Length of the linker group does not significantly alter spectral properties but does influence solubility and film morphology. The statistical distribution of phenylene vinylene segments along the copolymer backbone is discussed in the context of the optical profiles expected. Quantitative quenching of the luminescence for the shortest phenylene vinylene segments strongly indicates that crossover of excited states is occurring. The trapping and recombination of these excited states is occurring on lower-energy “islands”, confirmed to be the longer phenylene vinylene segments, which serve as ideal recombination sites for photogenerated species.

## Introduction

Poly(phenylene-*alt*-vinylene) is a broad-band semiconducting polymer, exhibiting strong luminescence in the green-yellow region of the visible spectrum. In 1990, Burroughes et al. reported the first light-emitting diodes (LED) based upon PPV films,<sup>1</sup> and since then, Holmes and co-workers have developed an ingenious route for the preparation of PPV copolymer precursors which, after processing at 200–300 °C in high vacuum to evolve HCl, form materials with luminescence systematically ranging from the green-blue through green-yellow region of the visible spectrum.<sup>2</sup> This route, however, appears to be incompatible with the formation of flexible LEDs prepared on polymeric substrates as reported by Heeger and co-workers.<sup>3</sup> The design of thermally stable, processible phenylene vinylene copolymers with tunable luminescence requires a new synthetic strategy.

At present, the preferred route for synthesis of PPV and its derivatives involves the direct coupling of bis(halomethyl) aromatics in basic solution, utilizing either (1) a precursor route<sup>4</sup> or (2) solubilizing side groups in order to maintain the growing rigid polymer chains in solution.<sup>5</sup> Yields are typically high—approaching 100% for some derivatives—and the molecular weight of the polymers ranges from tens or hundreds of thousands for the precursor route to the range of 1 million for the soluble PPV derivatives. The soluble PPV derivatives in particular are considerably “defect-free”, forming tunnel diodes with rectification ratios approaching 1 million.<sup>6</sup>

The high molecular weight and rapidity of reaction is consistent with a chain growth mechanism. Even at low conversions, molecular weights are high. Strong evidence has been forwarded for such a putative anionic mechanism,<sup>7</sup> in

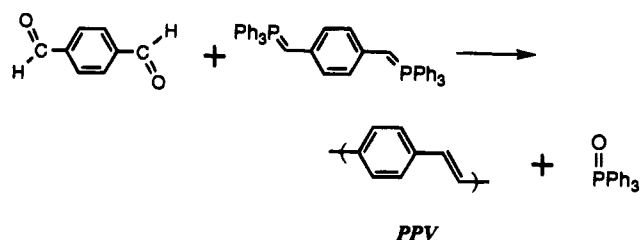

Figure 1. Wittig route to PPV.

which quinodimethanes are formed from the bis(halomethyl) aromatic monomer and subsequently coupled. These highly reactive intermediates tend to make the reaction uncontrollable and, in a chain growth polymerization, thwart copolymer design.

A less widely used route to PPV materials involves the Wittig-type coupling of dialdehydes with bis(phosphoranylidenes).<sup>8</sup> The reaction is a step-growth polycondensation, involving coupling of dialdehyde **A** and bis(phosphoranylidene) **B** monomers to form the stable vinylene bond in the new **AB** molecule.

The advantage of such a step-growth polymerization is that it allows more experimental control over the formation of copolymers. For instance, by using more than one type of dialdehyde in the polymerization mixture, the bis(phosphoranylidene) can react to form both **AB** and **A'B** species. In this study, **A'** is chosen so as to introduce a flexible linker in the polymer backbone, interrupting the PPV **ABABAB** conjugated blocks (Figure 2). The relative amount of **A'** incorporation is a function of the **A/A'** ratio present in the co-monomer reaction mixture. The higher the percentage of **A'**, the more flexible linker groups introduced along the polymer backbone, resulting in a copolymer with a lower average conjugation length (number of uninterrupted repeating phenylene vinylene units). The color of luminescence should therefore be somewhat “tunable” to the polymerization mixture ratios of reacting species.

## Experimental Section

**General Considerations.** Polymerizations were performed under nitrogen atmosphere. Reaction solvents were obtained as anhydrous and used without further purification. Glutaric dialdehyde was obtained

(7) Lahti, P. M.; Modarelli, D. A.; Denton, F. R., III; Lenz, R. W.; Karasz, F. E. *J. Am. Chem. Soc.* **1988**, *110*, 7258–9.

(8) McDonald, R.; Campbell, T. *J. Am. Chem. Soc.* **1960**, *82*, 4669. (a) Wadworth, W. S. *Org. React.* **1977**, *25*, 73–253. (b) Verbruggen, M.; Zhou, Y.; Lenstra, A. T. H.; Geise, H. J. *Acta Crystallogr.* **1988**, *C44*, 2120–3.

<sup>‡</sup> Present address: College of William and Mary, Williamsburg, VA 23187.

<sup>⊗</sup> Abstract published in *Advance ACS Abstracts*, June 15, 1995.

(1) Burroughes, J. H.; Bradley, D. D. C.; Brown, A. R.; Marks, R. N.; Mackay, K.; Friend, R. H.; Burns, P. L.; Holmes, A. B. *Nature* **1990**, *347*, 539.

(2) Burn, P. L.; Holmes, A. B.; Kraft, A.; Bradley, D. D. C.; Brown, A. R.; Gymer, R. W. *Nature* **1992**, *356*, 47.

(3) Gustafsson, G.; Cao, Y.; Treacy, G. M.; Klavetter, F.; Colaneri, N.; Heeger, A. J. *Nature* **1992**, *357*, 477.

(4) Wessling, R. A. *J. Polym. Sci., Polym. Symp.* **1985**, *72*, 55.

(5) Wudl, F.; Allemand, P. M.; Srdanov, G.; Ni, Z.; McBranch, D. *Materials for Non-linear Optics. ACS Symp. Ser.* **1991**, *455*, 683.

(6) Braun, D.; Heeger, A. J. *Appl. Phys. Lett.* **1991**, *58*, 1982–4.

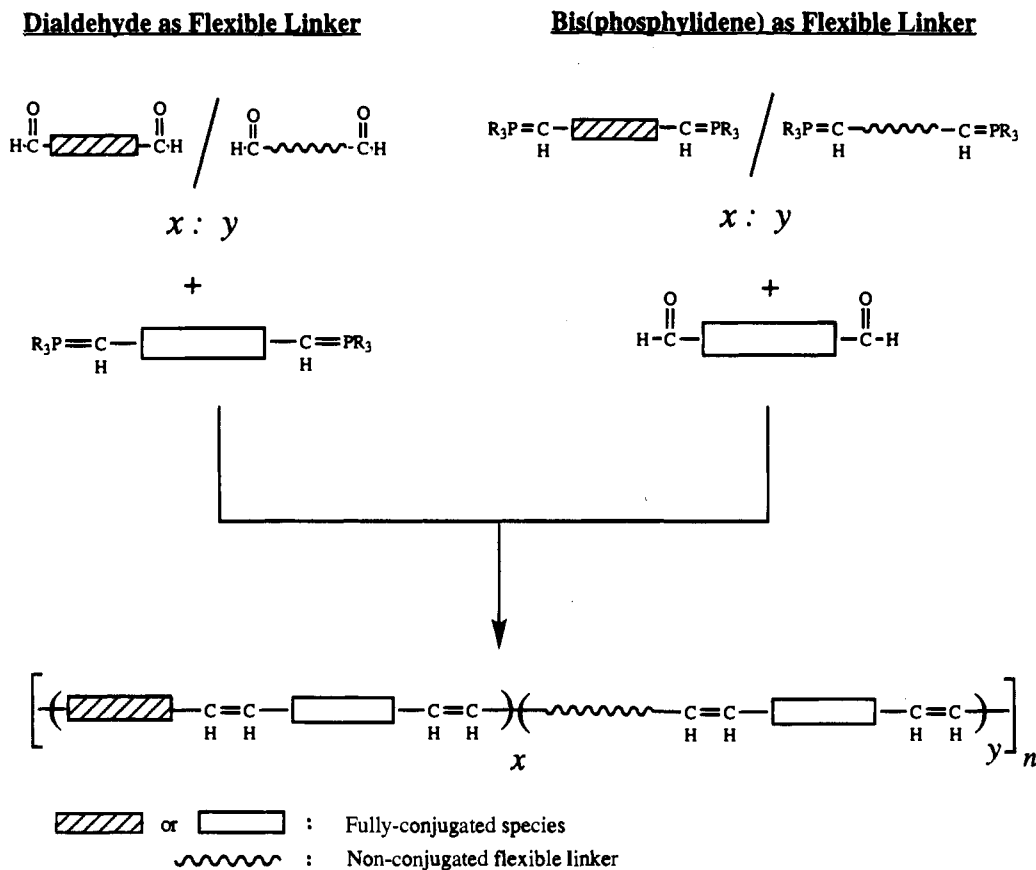

Figure 2. Wittig routes to aliphatic phenylene vinylene copolymers.

as a 50% aqueous solution (Aldrich) and fractionally distilled immediately prior to use. Potassium *tert*-butoxide solution in tetrahydrofuran (1 M) was purchased from Aldrich for use in the polymerizations. The bis(phosphonium) salt precursor to **3a** was prepared as previously reported.<sup>8</sup> All monomers were stored under nitrogen prior to use. Elemental analyses were performed by Galbraith Laboratories. Solution proton NMR were recorded using a GE 500 MHz spectrometer. Infrared spectra were obtained from a Midac Series 133 FT-IR. UV-visible spectra were recorded on an HP diode array spectrophotometer, as THF solutions (0.001% w/v) in quartz cuvettes. Corrected emission data were obtained by exposing THF solutions (0.040% w/v) in quartz cuvettes to 366 nm of Hg light (filter wavelengths > 380 nm) at a normal angle to a silicon photodetector. All spectra were recorded at a fixed geometry.

**Monomer 4b.** Vanillin (30.4 g, 0.20 mol), 1,6-dibromohexane (24.4 g, 0.10 mol), and excess potassium carbonate (35 g) were refluxed in 500 mL of DMF. After 6 h an equivalent volume of water was added and the precipitate was collected and dried. Recrystallization from THF gave 32.2 g (86.0%) of an isolated yield of white crystals, mp 160–161.5 °C. IR (KBr pellet,  $cm^{-1}$ ): 3340 (w), 2738 (w), and 1679 (s) peaks are characteristic of these dialdehydes. <sup>1</sup>H NMR (CDCl<sub>3</sub>, ppm): 9.84 (s, 2H, -CHO), 7.41–7.45 (triplet of doublets, 4H,  $J = 2$  Hz, 8 Hz, 11 Hz, -ArH), 6.98 (d, 2H,  $J = 8$  Hz, -ArH), 4.12 (t, 4H,  $J = 7$  Hz, -OCH<sub>2</sub>-), 3.92 (s, 6H, -OMe), 1.93 (m, 4H), 1.59 (m, 4H). MS:  $m/z$  (relative intensity) 386 ( $M^{+}$ , 25), 207 (100), 55 (75). Found (Calcd) for C<sub>22</sub>H<sub>26</sub>O<sub>6</sub>: C, 68.29 (68.38); H, 6.70 (6.78).

All dialdehyde monomers gave similar IR and NMR spectra (relative peak areas different).

**4c.** Synthesis as above. Yield 74.4%, mp 133–134 °C. MS:  $m/z$  (relative intensity) 414 ( $M^{+}$ , 19), 152 (100), 69 (46), 55 (27). Found (Calcd) for C<sub>24</sub>H<sub>30</sub>O<sub>6</sub>: C, 69.25 (69.55); H, 7.38 (7.30).

**4d.** Synthesis as above. Yield 80.0%, mp 105–106.5 °C. MS:  $m/z$  (relative intensity) 442 ( $M^{+}$ , 12), 152 (100), 55 (26). Found (Calcd) for C<sub>26</sub>H<sub>34</sub>O<sub>6</sub>: C, 70.38 (70.57); H, 7.86 (7.74).

**4a.** Synthesis as above. Yield 86.1%, mp 157–158 °C. MS:  $m/z$  (relative intensity) 358 ( $M^{+}$ , 5), 207 (100), 165 (57), 152 (21), 55 (75). Found (Calcd) for C<sub>20</sub>H<sub>22</sub>O<sub>6</sub>: C, 66.97 (67.03); H, 6.20 (6.19).

**Bis(diethyl phosphonato)xylylene Dichloride (3b).**  $\alpha, \alpha'$ -Dichloro-*p*-xylylene (25.0 g, 0.143 mol) and triethyl phosphite (47.5 g, 0.286 mol) were refluxed until ethyl chloride evolution had ceased, yielding 53.25 g (98.6%) of a waxy white solid.<sup>8a</sup> IR ( $cm^{-1}$ ): 2982, 1243, 1059, 963. <sup>1</sup>H NMR (CDCl<sub>3</sub>, ppm): 7.19 (s, 4H, -ArH), 4.01 (m, 8H, -POCH<sub>2</sub>-), 3.13 (d, 4H,  $J = 21$  Hz, -ArCH<sub>2</sub>P-), 1.24 (t, 12H, -CH<sub>3</sub>).

**Octamethylene-1,8-diylbis(triphenylphosphonium) Dibromide.** 1,8-Dibromooctane (2.72 g, 0.01 mol) was refluxed with an excess of triphenylphosphine (7.86 g, 0.03 mol) in 50 mL of DMF for 24 h. After being cooled to room temperature, the product was precipitated by addition of 100 mL of anhydrous ether under a nitrogen atmosphere. The white powder was collected and washed several additional times with ether until the ether washing showed no trace of triphenylphosphine or DMF by GC-MS analysis. Yield 7.52 g (95%), mp 261–264 °C. IR (KBr pellet,  $cm^{-1}$ ): 2980, 2930, 2870 (s, overlapping), 1670 (m), 1440 (m), 1385 (m), 1217 (m), 1110 (s), 760 (vs, broad). <sup>1</sup>H NMR (CDCl<sub>3</sub>, ppm): 7.71–7.86 (m, 30H, -ArH), 3.64–3.72 (m, 4H, -PCH<sub>2</sub>-), 1.64 (s, 8H, -PCH<sub>2</sub>CH<sub>2</sub>CH<sub>2</sub>-), 1.31 (s, 4H, innermost methylene protons). Found (Calcd) for C<sub>20</sub>H<sub>22</sub>O<sub>6</sub>: C, 66.11 (66.34); H, 5.77 (5.83).

**APV1 Copolymers.** **APV1-3-0.** Freshly distilled glutaraldehyde (0.502 g, 0.005 mol) was added to a septum-covered flask containing **3a** (3.495 g, 0.005 mol) and 0.5 g of LiCl in 25 mL of DMF. By syringe, 15 mL of a 1 M potassium *tert*-butoxide solution (in THF) was added dropwise, and after 6 h of stirring, the solution was acidified with 25 mL of 5% aqueous HCl. The dried powder was redissolved in chloroform, washed once with 2% HCl and twice with water, dried over anhydrous Na<sub>2</sub>CO<sub>3</sub>, then precipitated into an equal volume of EtOH. Isolated yield 527 mg (62%). IR (film,  $cm^{-1}$ ): 3008 m, 2928 s, 2853 m, 1599 w, 1514 m, 1118 s, 958 m (*trans* vinylene). <sup>1</sup>H NMR (CDCl<sub>3</sub>, ppm): 7.11–7.72 (broad), 6.48 (d), 6.19 (broad), 2.48 (m), 1.42 (m). Impurities in the aliphatic region hindered attempts at integration. Found (Calcd) for (C<sub>13</sub>H<sub>14</sub>)<sub>n</sub>: C, 90.59 (91.71); H, 8.01 (8.29).

**APV2 Copolymers.** **APV2-6-0.** Dialdehyde **4b** (1.00 g, 2.59 mmol) and the bis(phosphoranylidene) reagent **3a** (1.82 g, 2.60 mmol) were added to 25 mL of DMF containing 0.5 g of LiCl. Potassium

*tert*-butoxide (7.5 mL of 1 M in THF) was added dropwise with stirring, and after 6 h, the reaction was acidified with 25 mL of 5% HCl. Worked up as for APV1-3-0. Isolated yield 1.09 g (92%). IR (film,  $\text{cm}^{-1}$ ): 3009 m, 2938 s, 2851 m, 1681 w (residual aldehyde as end group), 1595 m, 1514 s, 1466 m, 1424 m, 1267 s, 1136 s, 1028 m, 966 m (*trans* vinylene).  $^1\text{H}$  NMR ( $\text{CDCl}_3$ , in ppm) 9.85 (s, trace, residual  $\text{H}-\text{C}(\text{O})-$ ), 6.98–7.58 (multiple splitting, 4H,  $-\text{Ar}-\text{H}$ ), 6.76 (d, 4H,  $\text{Ar}-\text{CH}=\text{CH}-$ ), 6.45 (m, 6H,  $-\text{Ar}(\text{OMe})-\text{H}$ ), 3.90 (t, 4H,  $-\text{OCH}_2-$ ), 3.65 (s, 6H, OMe), 1.78 and 1.48 (broad, total 8H, inner methylenes). Found (Calcd) for  $(\text{C}_{32}\text{H}_{36}\text{O}_4)_n$ : C, 79.12 (79.31); H, 7.40 (7.49). Inherent viscosity is 0.24 dL/g (0.1% solution in THF, w/v). The polymer is soluble in chloroform, chlorobenzene, THF, and DMF at a concentration of 10 mg/mL (1%). Polymer is refluxed in THF under nitrogen with a catalytic amount of iodine for 1 h; IR spectra of the sample before and after reflux are identical.

Except for peak intensities, the APV2 series of copolymers have similar IR and NMR spectral characteristics. For APV2-8-X and APV2-10-X polymers (octamethylene and decamethylene linker groups), an additional broad peak at  $\sim 1.37$  ppm is revealed by proton NMR. The  $\text{sp}^2$  splitting (6.5–7.5 ppm) becomes significantly more complex in the APV2-8-10, APV2-8-20, and APV2-8-40 copolymers, which contain phenylene vinylene segments of various lengths.

**APV2-6-10.** As above, using 0.90 g (2.33 mmol) of **4b** and 0.0343 g (0.259 mmol) of terephthalaldehyde in the initial DMF solution. Yield 967 mg (86%). Inherent viscosity is 0.26 dL/g (0.1% solution in THF, w/v).

**APV3 Copolymers. APV3-6-0.** Terephthalaldehyde (1.34 g, 0.01 mol) and the aliphatic bis(phosphonium) salt **5** (7.96 g, 0.01 mol) were dissolved in 25 mL of DMF. Potassium *tert*-butoxide (3.0 mL of 1 M in THF) was added and the reaction conducted as above for APV2-6-0. Yield 1.71 g (81%). IR (film,  $\text{cm}^{-1}$ ): 3022 m, 2928 m, 2854 m, 1604 m ( $-\text{CH}=\text{CH}-$ ), 1516 m, 1438 w, 1424 w, 1116 m, 968 s (*trans* vinylene).  $^1\text{H}$  NMR ( $\text{CDCl}_3$ , ppm): 7.25 (s, 4H,  $-\text{ArH}$ ), 6.34 (d, 2H,  $J = 16$  Hz,  $-\text{ArCH}-$ ), 6.19 (d and t, 2H,  $J = 14$  Hz,  $-\text{ArCHCH}-$ ), 2.20 (m, 4H,  $-\text{CHCH}_2-$ ), 1.48 and 1.36 (both singlets, inner methylene protons, integration hindered by impurities). Found (Calcd) for  $(\text{C}_{16}\text{H}_{20})_n$ : C, 91.84 (92.26); H, 7.56 (7.74). Inherent viscosity is 0.16 dL/g (0.1% solution in THF, w/v).

Except for peak intensities, the APV3 series of copolymers all have similar IR and NMR spectral characteristics.

**APV3-6-20. Method A.** Terephthalaldehyde (1.34 g, 0.01 mol), aliphatic bis(phosphonium) salt **5** (6.37 g, 0.008 mol), and aromatic bis(phosphonium) salt **3a** (1.40 g, 0.002 mol) were dissolved in 25 mL of DMF and polymerized as for APV3-8-0. Yield 1.60 g (76%). Inherent viscosity is 0.22 dL/g (0.1% solution in THF, w/v).

**Method B (Single-Pot Reaction).** The mixture of aliphatic and aromatic bis(phosphonium) salts was generated *in situ* by refluxing 1,8-dibromooctane (4.36 g, 0.016 mol) and  $\alpha,\alpha'$ -dichloro-*p*-xylene (0.70 g, 0.004 mol) with triphenylphosphine (10.48 g, 0.04 mol) in 50 mL of DMF. After 24 h the flask was cooled and terephthalaldehyde (2.68 g, 0.02 mol) was added. The reaction was conducted as above. Yield 3.44 g (82%). Inherent viscosity is 0.18 dL/g. Spectra from this sample are nearly identical to those from method A.

## Results

**Polycondensation Tactics.** In these polymerizations, terephthalaldehyde, xylylenebis(triphenylphosphonium) dichloride, and a flexible linker are coupled in varying proportions. The flexible linker is incorporated into the coupling reactions because it contains either two aldehyde end groups (Schemes 1 and 2) or two phosphoranylidene end groups (Scheme 3). Schemes 1 and 2 in particular are ideal methods for randomly incorporating a flexible linker into the PPV backbone, since both of these schemes involve a highly reactive intermediate [the bis-(phosphoranylidene)] as the coupling agent for the dialdehyde co-monomers (terephthalaldehyde [**A**] and flexible dialdehyde linker [**A'**]). The more reactive the intermediate, the lower the activation energy for coupling and the less it will discriminate

## Scheme 1. APV1 Series

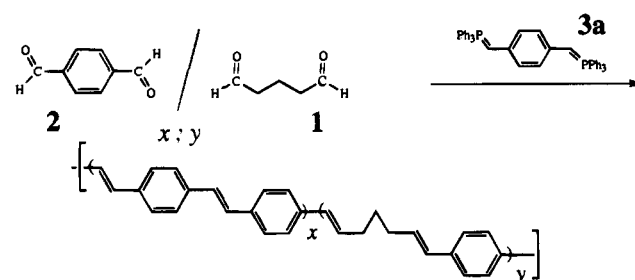

between reacting with co-monomer **A** or **A'**, resulting in a truly random incorporation of flexible linker **A'** along the PPV backbone.<sup>9</sup>

Initial attempts at incorporating a flexible linker into the phenylene vinylene polymer backbone involved glutaraldehyde (Scheme 1). Although they are commercially available, the tendency for aliphatic dialdehydes to undergo reversible self-polymerization requires purification by distillation immediately prior to use in each experiment. The more stable aromatic nonconjugated dialdehydes used in Scheme 2 are synthesized by condensation of vanillin with aliphatic dihalides in a basic medium. The method is convenient and subject to high yields and allows for the preparation of a specified length of alkyl linker group. Researchers at Amherst have previously used similar dialdehydes in Wittig polycondensations, forming discreet distyrylbenzene units in a flexible polymer backbone used in electroluminescent devices.<sup>10</sup>

In these studies, terephthalaldehyde was the only *conjugated* dialdehyde used. Both Emmons (phosphonate) and Wittig (phosphonium salt) reagents have been previously used as the bis(phosphoranylidene) source in phenylene vinylene polymerizations,<sup>8</sup> but the Wittig reagent appears to give consistently higher yields for these APV copolymers.

**Nomenclature of Copolymers.** Each aliphatic phenylene vinylene (APV) derivative is named according to the synthetic methodology used, so that all the APV2 polymers are prepared through Scheme 2. These polymers are further differentiated through the nomenclature APV2-L-X, where L is the number of methylene units in the polymer's flexible linker and X is the molar percentage of the "conjugated" [*nonflexible*] co-monomer in the feed ratio (equal to the "PPV content" of the APV copolymer prepared). Thus, the copolymer prepared through condensing a 40:60 ratio of **4c/2** with the Wittig reagent **3a** is referred to as APV2-8-60, whereas the copolymer prepared in Scheme 1 using a 90:10 ratio of glutaraldehyde (**1**, where  $m = 3$ )/**2** is referred to as APV1-3-10. This nomenclature is particularly useful considering the various permutations involved in these copolymerization schemes.

**Polymer Characterization.** The APV2-8-X and APV3-6-X copolymers with greater than 40% flexible linker groups are readily soluble in organic solvents. However, APV1 copolymers are soluble only when the flexible linker (glutaraldehyde) in the co-monomer mixture is about 80% or higher. All of the polymers listed in Table 1 are solution processible into pinhole-free films.

Proton NMR spectra for the APV2 and APV3 series are fully consistent with the expected structures. In APV2-8-0 and APV3-6-0, coupling constants of 14 Hz for the vinylene protons

(9) In the alternative case in which the selectivity between **A** and **A'** is great, a highly blocked copolymer is formed containing long PPV segments even at high incorporation of flexible linker; that is, experimental control over conjugation length is lost if the coupling rates of **A** and **A'** are substantially different.

(10) Yang, Z.; Sokolik, I.; Karasz, F. E. *Macromolecules* **1993**, *26*, 1188–9.

Scheme 2. APV2 Series

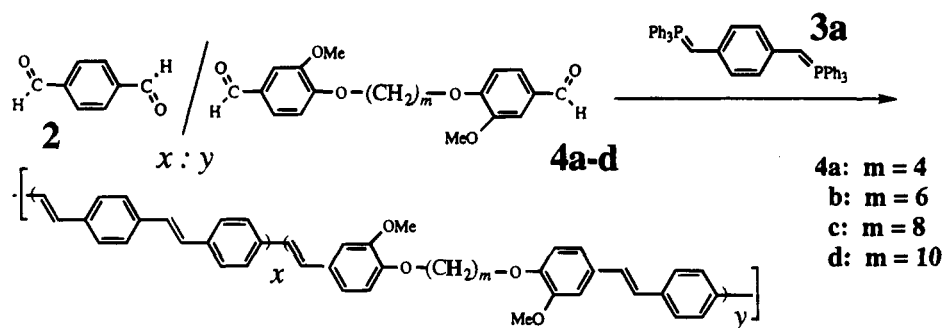

Scheme 3. APV3 Series

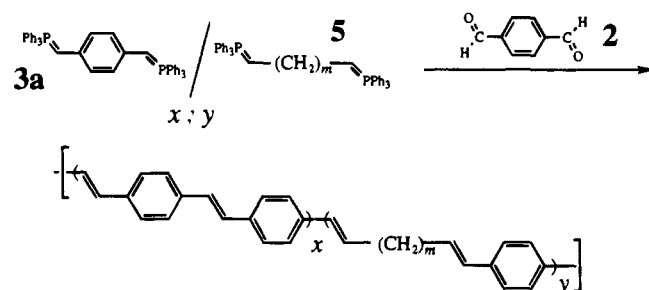

suggest a predominantly *trans* configuration for the double bonds.<sup>11</sup> After refluxing with a catalytic amount of iodine under nitrogen to effect *cis* → *trans* isomerization,<sup>8b</sup> the IR spectra remain unchanged, further implying a predominantly *trans* configuration. The APV series UV–visible absorption spectra contain peaks ascribable to conjugated phenylene vinylenes, and the luminescent spectra exhibit vibronic substructure with a wavenumber (1300 cm<sup>-1</sup>) characteristic of the phenylene vinylene excited state.

In the APV2-8-X series, each flexible linker group incorporated into the copolymer backbone contributes 12 protons with NMR shift 1–2 ppm (six inner methylenes—those not attached to the phenolic oxygens) and contributes a total of 14 protons attached to sp<sup>2</sup> carbon atoms. Each nonflexible dialdehyde (terephthalaldehyde) incorporated contributes zero methylene protons and 12 protons attached to sp<sup>2</sup> carbons. Simple deconvolutional analysis provides a theoretical methylene vs sp<sup>2</sup> integration ratio for any APV2-8-X copolymer (Table 2). NMR integration provides concrete evidence that the *copolymer composition does indeed reflect the co-monomer ratio* used in its preparation.

Proton NMR and IR reveal trace carbonyl functionalities in these polymers, presumably due to the aldehyde end groups, below reliable limits of proton NMR integration (less than a few percent). Molecular weights of these APV polymers are moderately low as evidenced by the inherent viscosities; still, pinhole-free films are obtained with high quality from concentrated (1%) solutions of all polymers listed in Table 1.

Composition of the APV polymer is likewise crucial to solid state properties, as evidenced by APV1-3-10 and APV2-8-10 films. In the first case where the polymer is synthesized with a flexible linker containing only three methylene units (glutaraldehyde), the resulting film undergoes perfect 90° phase contrast under rotation of plane-polarized light, indicating a high degree of preferential ordering. With the longer flexible linker group in APV2-8-10, the polymer film appears amorphous.

**Absorption Spectra.** The APV2-8-0 (A'B)<sub>n</sub> homopolymer is a well-defined structure containing alkoxy-substituted distyryl-

benzene units electronically isolated from each other by octamethylene glycol linkers. The spectrum of APV2-8-0 is transparent in the visible region with λ<sub>max</sub> = 348 nm, blue-shifted in comparison to the analogous alkoxy-substituted distyrylbenzene molecule (λ<sub>max</sub> = 374 nm).<sup>12</sup> By incorporating 40% of terephthalaldehyde into the polymerization (creating longer PPV segments throughout the backbone), the primary π → π\* band edge is shifted by 20 nm (0.15 eV) toward lower energy with satellite peaks extending well into the visible (see Figure 3), so that APV2-8-40 is bright yellow. The higher energy band at 235 nm—most likely associated with localized electronic states within the phenyl rings—is less affected by the differences in π-conjugation of such materials as APV2-8-0 and APV2-8-40.

The APV1-3-0 and APV3-8-0 polymers have a band edge for the predominant peak at 340 nm (λ<sub>max</sub> = 320 nm), significantly greater in energy than the APV2-8-0 polymer. These data are reconciled by structural considerations: whereas in APV2-8-0 the discreet conjugated units are distyrylbenzenes (three phenylenes separated by two vinylenes), in APV1-3-0 and APV3-8-0 the discreet units are the less conjugated divinylbenzene units (two vinylenes separated by one phenylene). In fact, the optical spectrum of pure divinylbenzene has a *sharp* absorption edge at 340 nm. Both APV1 and APV3 polymers have absorption peaks extending into the visible,<sup>13</sup> leaving the APV2 series as the polymers of choice for photoluminescence studies in which the absorption and emission spectra for any given sample are not overlapping.

**Emission Spectra.** The most dramatic result of varying the average conjugation length in these APV copolymers is the *systematic* red-shifting of the photoluminescence as the flexible linker percentage in the co-monomer feed ratio is decreased (Figure 4), providing evidence that the distribution of conjugated segments is indeed fairly random. In the APV2 series at 0% terephthalaldehyde (1) incorporation, the polymer luminesces blue in solution. With 10% **2**, the copolymer luminesces blue-green. With 20% and 40% **2**, the luminescence shifts into the green and yellow-green, respectively. It is interesting to note that APV2-8-0 shows no fine structure in the luminescence spectrum, whereas the more rigid APV2-8-40 does exhibit vibronic substructure. The nature and fate of these excitations are considered further in the Discussion.

Solution photoluminescence spectra of copolymer samples APV2-4-20, APV2-6-20, APV2-8-20, and APV2-10-20 are compared in Figure 5. In this study, the amount of the flexible linker was kept constant from sample to sample, but the length

(12) Heller, A. *J. Chem. Phys.* **1964**, *40* (10), 2839.

(13) Some defects in the APV1 polymerization might result from oligomers being present in the glutaraldehyde monomer (aliphatic aldehydes are known to undergo self-polymerization; see, for example: Windholz, M., Ed. *Merck Index*, 10th ed.; Merck & Co.: Rahway, NJ, 1983; pp 4333–4). Defects in the APV1 and APV3 polymers possibly arise from cross-linking of the divinylbenzene units upon absorption of light.

(11) Silverstein, R.; Bassler, G.; Morrill, T. *Spectrometric Identification of Organic Compounds*, 4th ed.; John Wiley and Sons: New York, 1981, p 235.

**Table 1.** APV Polymers Prepared

sample	glutaraldehyde	terephthalaldehyde	bis(phosphoranylidene)	yield (%)
APV1-3-0 <sup>a</sup>	100	0	100 (3a)	62
APV1-3-10	90	10	100 (3a)	49
APV1-3-20	80	20	100 (3a)	45

sample	dialdehyde	terephthalaldehyde	bis(phosphoranylidene)	yield (%)
APV2-8-0	100 (4c)	0	100 (3a)	94
APV2-8-10	90 (4c)	10	100 (3a)	86
APV2-8-20	80 (4c)	20	100 (3a)	88
APV2-8-40	60 (4c)	40	100 (3a)	89
APV2-8-60	40 (4c)	60	100 (3a)	82
APV2-8-0-b	100 (4c)	0	100 (3b)	81
APV2-6-0	100 (4b)	0	100 (3a)	92
APV2-6-20	80 (4b)	20	100 (3a)	86
APV2-4-0	100 (4a)	0	100 (3a)	84
APV2-4-20	80 (4a)	20	100 (3a)	77
APV2-10-0	100 (4d)	0	100 (3a)	85
APV2-10-20	80 (4d)	20	100 (3a)	86

  

sample	terephthalaldehyde	aliphatic bis(ylide)	aromatic bis(ylide)	yield (%)
APV3-8-0	100	100 (5)	0 (3a)	81
APV3-8-20	100	80 (5)	20 (3a)	82

<sup>a</sup> Example: 100 mmol of glutaraldehyde, 0 mmol of terephthalaldehyde, and 100 mmol of bis(phosphylidene) **2a** are reacted to yield the copolymer sample APV1-3-0.

**Table 2.** Proton NMR Integration of APV2 Copolymers

sample	theoretical H <sub>A</sub> /H <sub>D</sub> ratio	obsd ratio	Δ (%)
APV2-8-0	14/12	53/48	+5.3
APV2-8-20	17/12	47/35	+5.2
APV2-8-40	22/12	57/34	+8.5

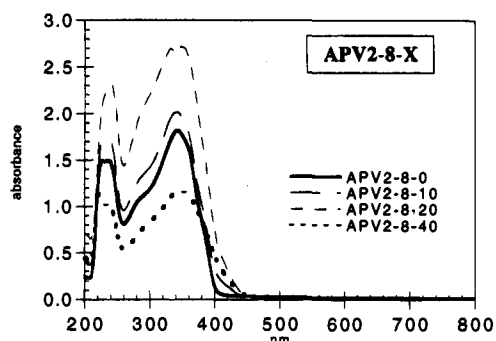
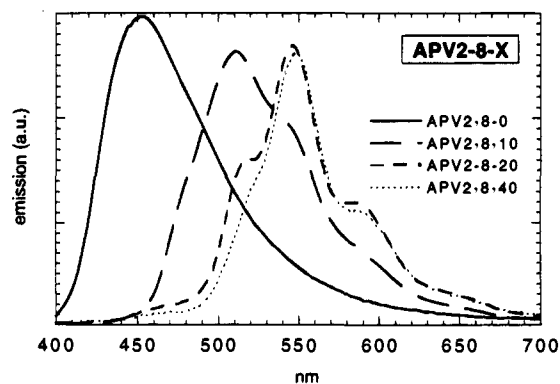
**Figure 3.** Solution absorption spectra for APV2 copolymers having different PPV contents.**Figure 4.** Solution emission spectra for APV2 copolymers having different PPV contents.

of the linker was systematically varied. The spectra are all similar, indicating virtually no effect of the linker length upon the color of luminescence.<sup>14</sup>

**Statistical Considerations.** Figure 6 reveals the calculated density profiles<sup>15</sup> for purely random APV2-L-0, APV2-L-10,

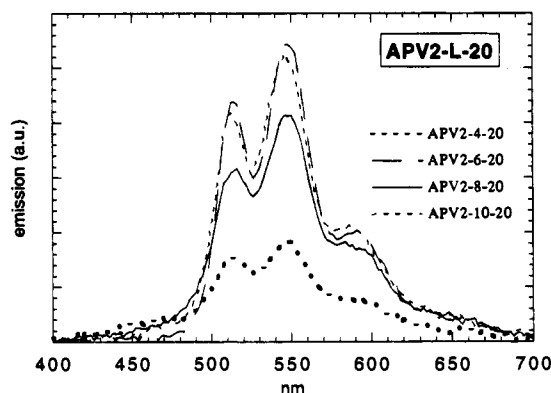
**Figure 5.** Solution emission spectra for APV2 copolymers with similar PPV content, but having different length of linker groups.

APV2-L-20, and APV2-L-40 copolymers, where the nature of the linker group is statistically unimportant. For example, the APV2-8-20 random copolymer has nearly five times as many conjugated segments consisting of precisely three phenylenes and two vinylenes as the number of conjugated segments having precisely five phenylenes and four vinylenes. Thus, if the luminescence spectra of these two species are mutually non-interfering, the 3/2 peak which comprises 100% of the photoluminescence in APV2-8-0 should in APV2-8-20 now exhibit a lower-energy shoulder with about one-fifth the intensity—dependent upon the extinction coefficients and quantum efficiency for luminescence of 3/2 vs 5/4.

Clearly this is not the case. APV2-8-20 exhibits virtually no emission at the energy where APV2-8-0 has its peak emission (Figure 4). Emission is not occurring from 3/2 units in APV2-8-20 to any appreciable extent. The 3/2 distyrylbenzene units

(14) The lack of a correlation between optical processes and length of the linker is not unexpected and has been reported previously for distyrylbenzene units separated by a linker group (Yang, Z.; Sokolik, I.; Hu, B.; Karasz, F. E. *Polymeric Materials: Science and Engineering*. ACS National Meeting, Chicago, IL, 1993; American Chemical Society: Washington, DC, 1993; p 155). In the case of the APV2-L-20 series, the overlap of spectra also demonstrated that the polycondensation statistics are unchanged by varying the linker group—that is, the reactivities of all dialdehyde linkers are essentially identical.

(15) From previous use of this statistical modeling: Klavetter, F. L. Ph.D. Thesis Dissertation, California Institute of Technology, Pasadena, CA, 1989.

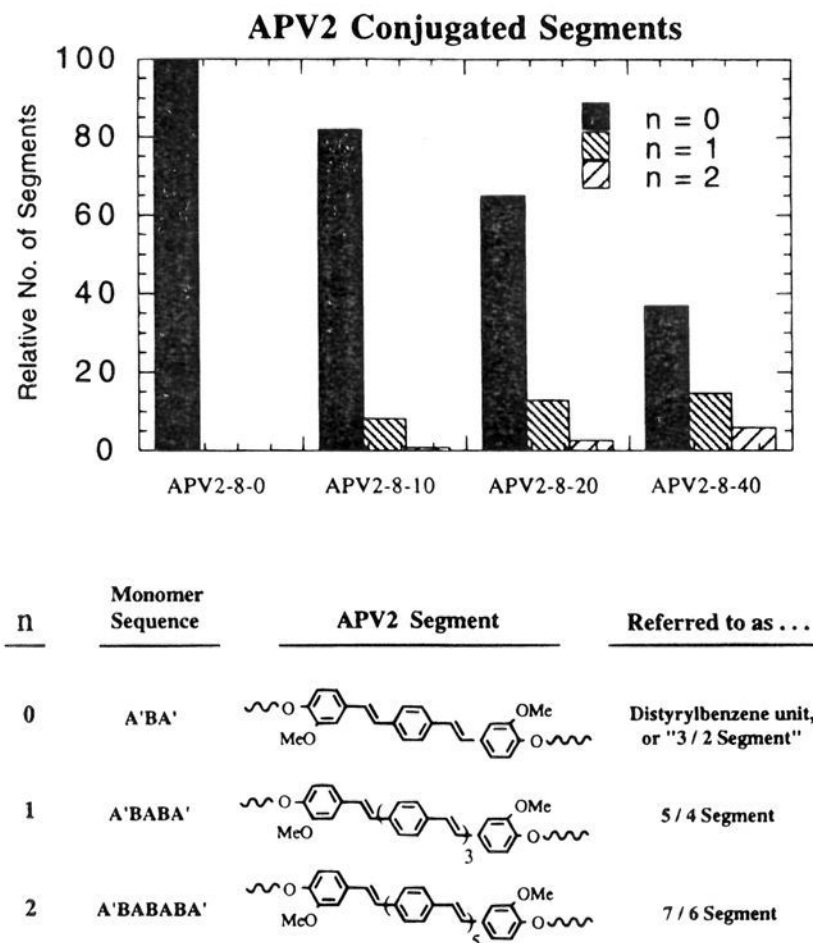

**Figure 6.** Calculated densities of various phenylene vinylene segment lengths ( $n = 0, 1, \text{ or } 2$ ) within a random APV copolymer chain containing 100 units (AB or A'B). The relative amounts of phenylene vinylene segments are calculated for each of the four cases where the mole fraction of A is 0, 0.1, 0.2, or 0.4—the "PPV content" in the copolymer backbone.

are present in APV2-8-20; in fact, they represent the overwhelming majority of conjugated segments. That the 3/2 segments are readily photoexcited by a 366 nm light source is confirmed by the strong luminescence of APV2-8-0. However, in the presence of additional 5/4 (and 7/6, 9/8, 11/10) phenylene vinylene segments contained in the APV2-8-20 copolymer, the 3/2 luminescence is nearly quantitatively quenched.

**Photosensitization.** A mechanism for this quenching of 3/2 luminescence is proposed in Figure 7. The excited 3/2 segment comes in contact with a 5/4 segment, electron exchange occurs ( $\pi^*$  electron from the 3/2 segment is transferred to the lower energy  $\pi^*$  orbital of the 5/4 segments, while concomitantly in this close contact situation a  $\pi$  electron from this 5/4 segment transfers an electron to the lower energy  $\pi$  orbital vacancy ("hole") in the 3/2 segment),<sup>16</sup> and electron-hole recombination occurs on the longer conjugated segment yielding lower energy radiation than that observed from 3/2 photoluminescence. The photoluminescence peaks observed in APV2-8-10 (perhaps due to both 5/4 and 7/6 emission) and in APV2-8-20 have vibronic spacing characteristic of the excited state C=C PPV stretch ( $1300 \text{ cm}^{-1}$ ),<sup>17</sup> confirming that longer phenylene vinylene segments are the species being photosensitized.

## Discussion

In these APV polymerizations the color of luminescence is determined through a chain of considerations relating

(16) All levels of molecular orbital calculations indicate that, as like-symmetry orbitals are coupled, new delocalized orbitals are created at both higher and lower energies than the initial states. For  $\pi$ -symmetry states, lengthening the conjugation with similar energy species [3/2 segment + two phenylene vinylenes  $\rightarrow$  5/4 segment] always results in a raising of the HOMO and lowering of the LUMO energy, as depicted in Figure 10. (Jorgensen, W.; Salem, L. *The Organic Chemist's Book of Orbitals*; Academic Press: New York, 1973; pp 10–11.)

(17) Friend, R. H.; Bradley, D. D. C.; Townsend, P. D. *J. Phys. D.: Appl. Phys.* **1987**, *20*, 1367.

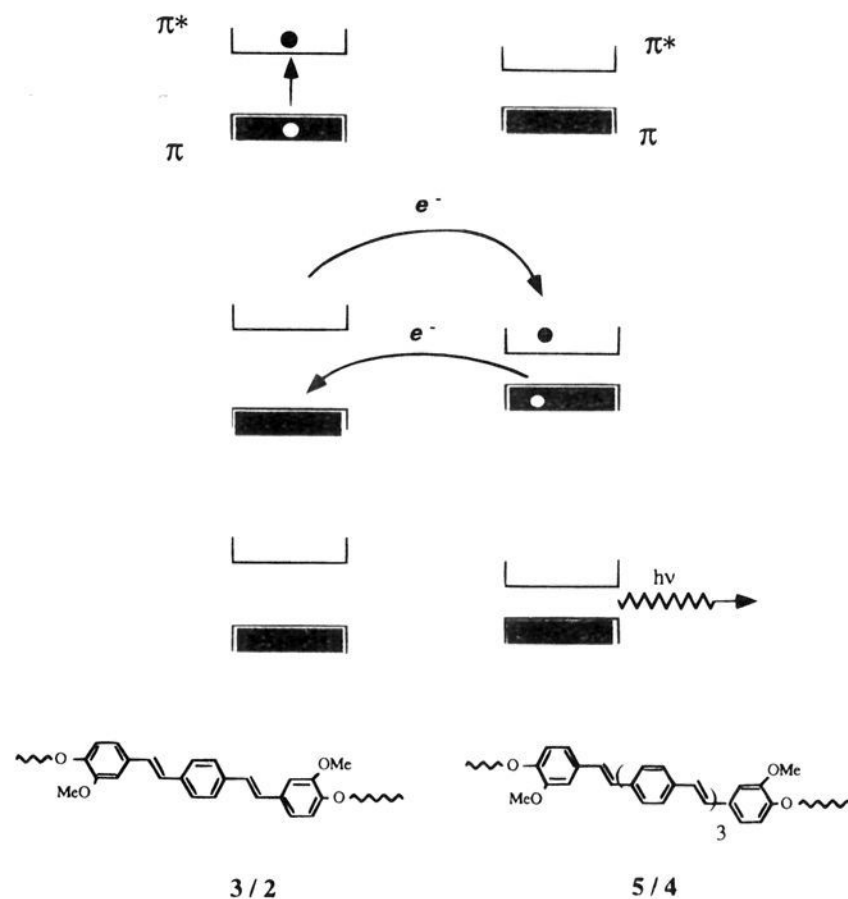

**Figure 7.** Exciton transfer from 3/2 to 5/4 segments in APV2 copolymers. Photoexcitation creates a hole–electron pair on one of the 3/2 segments (top), which is transferred to the lower band gap 5/4 segment (middle), undergoing relaxation and recombination with generation of a photon (bottom).

back to the co-monomer feed ratio:

$$\begin{array}{l} A/A' \rightarrow \text{average conjugation length} \rightarrow \\ \text{(ratio)} \qquad \qquad \qquad \text{(structure)} \\ \text{HOMO–LUMO gap} \rightarrow \text{emission} \\ \text{(orbital energies)} \qquad \qquad \text{(color)} \end{array}$$

On average, increasing the PPV content decreases the energy of luminescence: APV2-8-0 through APV2-8-20 fluoresce blue through green, respectively. Absorption/emission processes, however, are not merely averaged; the spectral profiles contain a wealth of information on energy dependence and time dependence of the luminescence. Likewise, the average PPV content must be considered in terms of a distribution of PPV segments having various lengths; the PPV content of APV2-8-10 is different than that in APV2-8-20 in both a quantitative and qualitative definable manner. The quantitative distribution of these segments is governed by statistics, and the characteristic properties and energies have been previously reported (Table 3).

Consider the fate of an excited state in APV2-8-0, a polymer comprised 100% of 3/2 units separated by flexible linkers. Upon irradiation in the near UV, the 3/2 species undergo photoexcitation ( $10^{-15} \text{ s}$ ) to form hole–electron excitons. Within a few vibrations ( $10^{-12} \text{ s}$ ) the segment relaxes to a planar rigid structure<sup>18</sup> with quinoidal character in the phenylene units to promote delocalization of the newly created charges, thus stabilizing the exciton and lowering its band gap. After 1–2 ns, the exciton decays radiatively with a Stokes shift in the luminescence. For discrete distyrylbenzene molecules in toluene (an analogous 1/0  $\rightarrow$  3/2 phenylene vinylene photosensitization), this radiative pathway occurs with 100% quantum efficiency.<sup>18</sup>

(18) Bush, T. E.; Scott, G. W. *J. Phys. Chem.* **1981**, *85* (2), 144.

(19) Oberski, J. M.; Greiner, A.; Bäessler, H. *Chem. Phys. Lett.* **1991**, *184* (5–6), 391.

(20) Berlman, I. B. *Handbook of Fluorescence Spectra of Aromatic Molecules*; Academic Press: New York, 1971.

(21) Pichler, K.; Halliday, D. A.; Bradley, D. D. C.; Burn, P. L.; Friend, R. H.; Holmes, A. B. *J. Phys.: Condens. Matter* **1993**, *5*, 7155.

**Table 3**

segment	absorption		emission		lifetime (ns)
	peak (nm)	0-0 line (nm)	peak (nm)	0-0 line (nm)	
3/2 (soln)	355 <sup>12,18</sup>	370 <sup>18,19</sup>	414 <sup>12,18</sup>	400 <sup>12,18</sup>	1-2 <sup>20</sup>
3/2 (soln)	374 <sup>12</sup>	390 <sup>18</sup>	436 <sup>12</sup>	415 <sup>12,18</sup>	1-2 <sup>12</sup>
5/4 (soln)		435 <sup>19</sup>			
PPV (film)	435 <sup>17,21</sup>	486 <sup>17,21</sup>	565 <sup>17</sup>	620 <sup>17</sup>	<0.1 <sup>17</sup>
PPV <sup>b</sup> (film)	515 <sup>21</sup>	515 <sup>21</sup>	516 <sup>21</sup>	516 <sup>21</sup>	

<sup>a</sup> Tetraalkoxy-substituted, <sup>b</sup> High-quality PPV, at a temperature of 15 K.

In APV2-8-10 the ratio of 3/2, 5/4, and 7/6 segments is roughly 100:10:1 (Figure 6). Upon photoexcitation, however, the 3/2 segments are not fluorescing. Friend *et al.* have previously concluded that "following photo-excitation and prior to emission there is probably a rapid migration of excited states" in PPV.<sup>17</sup> Even though in the APV2-8-X copolymers each 3/2 segment is electronically isolated from the 5/4 segments by a *minimum* of 10 covalently bound sp<sup>3</sup> atoms in the flexible linker (several linkers may separate the 3/2 from its nearest 5/4 neighbor), photoexcited states are transferred to longer conjugation length segments. The 3/2 overlap with 5.4 segments occurs with minimal entropy cost, and because the exciton transfer is strongly enthalpically favorable, the barrier for back-transfer (band-gap difference between 3/2 and 5/4 segments: 0.5 eV or ~200 kT) is considerable. In addition, according to Wigner's rule of spin conservation, electron exchange between segments proceeds with retention of singlet pairing, so that no radiative recombinative probability is lost during the transfer.

An alternative possibility is that just one spin state (either hole or electron) transfers to another chain, breaking up the singlet exciton. The barrier for a PPV singlet exciton to dissociate into a negative polaron (delocalized radical anion) and positive polaron (delocalized radical cation) has been reported experimentally<sup>22</sup> and theoretically<sup>23</sup> to be less than 0.05 eV. Certainly this binding energy is greater in these smaller phenylene vinylene segments, but even given the *intrachain* dissociation of a singlet exciton, transferring only a single polaron from 3/2 to 5/4 is energetically expensive. The system loses roughly 0.25 eV (one-half the band gap difference) in not transferring the second polaron, plus it suffers the energetic requirements of separating positive and negative charges onto different segments. Therefore, it seems reasonable to conclude that the observed bleaching of 3/2 segments is the result of *intact singlet exciton transfer* to longer conjugated segments.

In APV2-8-20, the ratio of 3/2, 5/4, and 7/6 segments is roughly 25:5:1. For this spectrum and for APV2-8-40, it is difficult to distinguish vibronic structure from overlapping peaks, but with increasing PPV content, the spectra continue to be red-shifted at the expense of bleaching the 3/2 emission. Even though the PL spectra for APV2-8-20, APV2-8-40, and APV2-8-60 are almost overlapping in profile, the phenylene vinylene segment densities for these copolymers are certainly very different. The intrachain coherence length of delocalized excited states saturates at around eight phenylene vinylene units for

standard PPV<sup>23,24</sup> but is increased to roughly 15 units for higher quality PPV samples,<sup>21</sup> suggesting that the increased concentrations of 9/8, 11/10, 13/12, and 15/14 phenylene vinylene segments may play an important role in the luminescence (photoexcited lifetimes, recombination efficiencies) for such a copolymer as APV2-8-60.

In the APV copolymers, the Stokes shift is not meaningful in the conventional sense, as the absorption and emission are occurring from different species. In the APV2-8-0 homopolymer, where absorption and emission are both occurring from a distyrylbenzene moiety, the 0-0 low energy edge of the spectra cannot be precisely determined. The broadness and lack of fine structure in the APV2-8-0 absorption peak indicates an inhomogeneity of states, resulting from varying "twistedness" from planarity of the 3/2 segment. Both the physical constraints of (1) being bound within a polymer coil and (2) being dissolved in solution contribute to this increased dihedral angle, which results in the observed blue-shifting of the APV2-8-0 peak absorption compared with the model tetraalkoxydistyrylbenzene compound. The red-shifting of the APV2-8-0 emission peak relative to the model compound, coupled with the lack of fine structure, suggests a mixing of the 3/2 excited states (excimer formation): the coiled polymer represents a concentrated environment of the 3/2 segments, and distyrylbenzenes are well-known for their excimer formation at high concentrations.<sup>26</sup> For the APV2-8-20 and APV2-8-40 copolymers, the presence of vibronic structure specifically indicates homogeneity in the geometry of the emitting species: the excited phenylene vinylene is essentially planar (excitation mixes the single- and double-bond states so that there is a substantial barrier for rotation),<sup>23</sup> and the longest segments are energetically isolated so as to preclude excimer formation, which would mix the quantum states to broaden the emitting species energy. All the optical data are consistent with the picture of longer phenylene vinylene islands in a sea of distyrylbenzene units: in the APV2-8-0 homopolymer, the sea is doing the emitting; in the copolymers, the islands are the emitters.

**Acknowledgment.** We are grateful to Dr. Y. Yang for assisting with the PL data. We appreciate the undergraduate research fellowship provided to M.H. by UNIAX Corp., and appreciatively acknowledge Phase I and Phase II funding obtained from the National Science Foundation through a Small Business Innovative Research Award III-9302949.

**Supporting Information Available:** Proton NMR spectra of copolymers, solution absorption spectra of APV1 and APV3 polymers, and micrographs of amorphous vs crystalline-ordered copolymers (5 pages). This material is contained in many libraries on microfiche, immediately follows this article in the microfilm version of the journal, can be ordered from the ACS, and can be downloaded from the Internet; see any current masthead page for ordering information and Internet access instructions.

JA950620D

(24) Mahrt, R.; Yang, J.-P.; Greiner, A.; Bässler, H.; Bradley, D. D. C. *Makromol. Chem., Rapid Commun.* **1990**, *11*, 415.

(25) Heller, A. *J. Chem. Phys.* **1962**, *36* (11), 2858.

(26) Distyrylbenzene derivatives are commercially available as excimer laser dyes.

(22) Lee, C. H.; Yu, G.; Moses, D.; Heeger, A. J. *Phys. Rev. B* **1994**, *49* (4), 2396.

(23) Shuai, Z.; Bredas, J. L.; Su, W. P. *Chem. Phys. Lett.*, submitted.